

Installation Plan

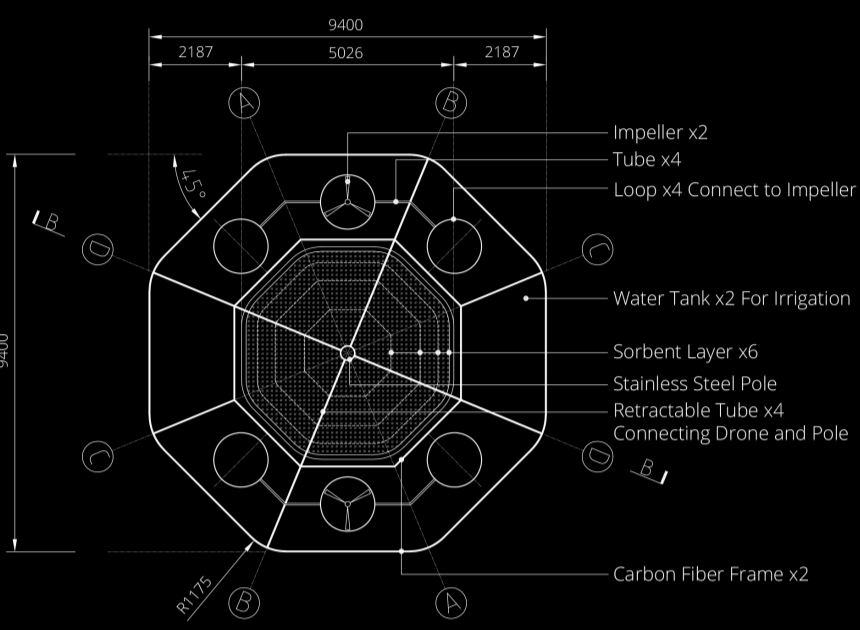

A-A Section

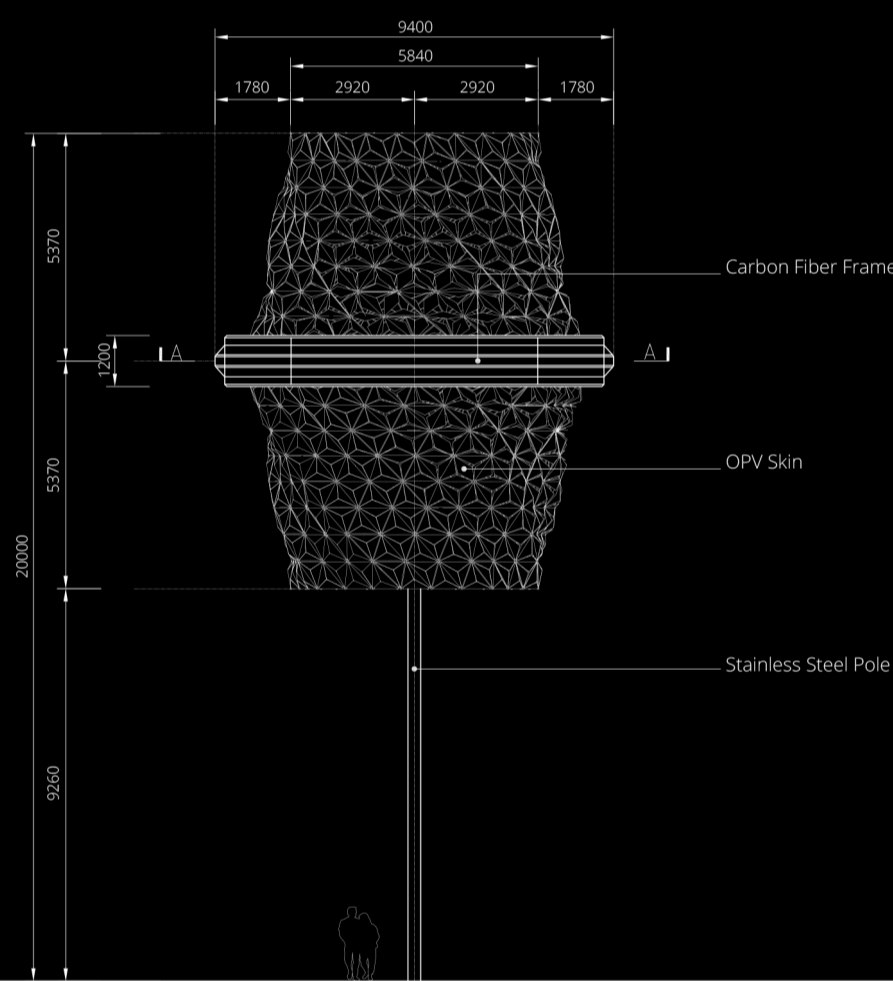

Installation Elevation

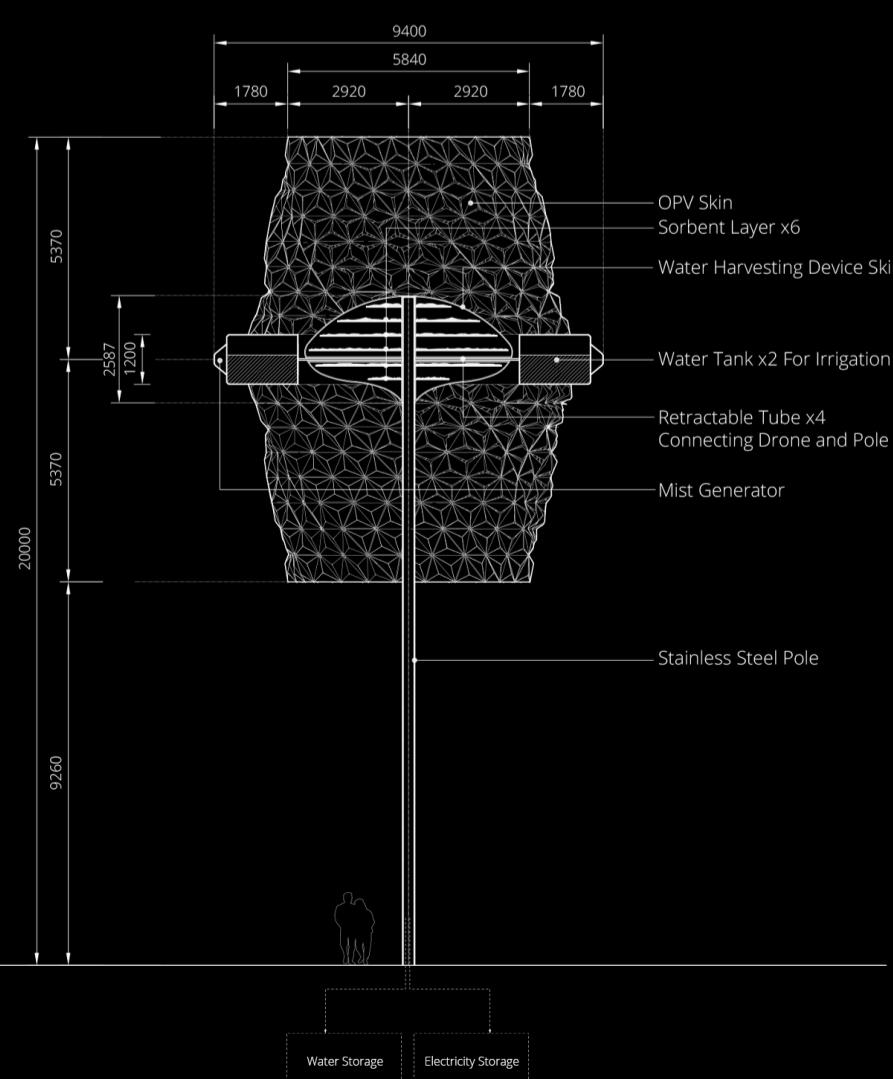

B-B Section

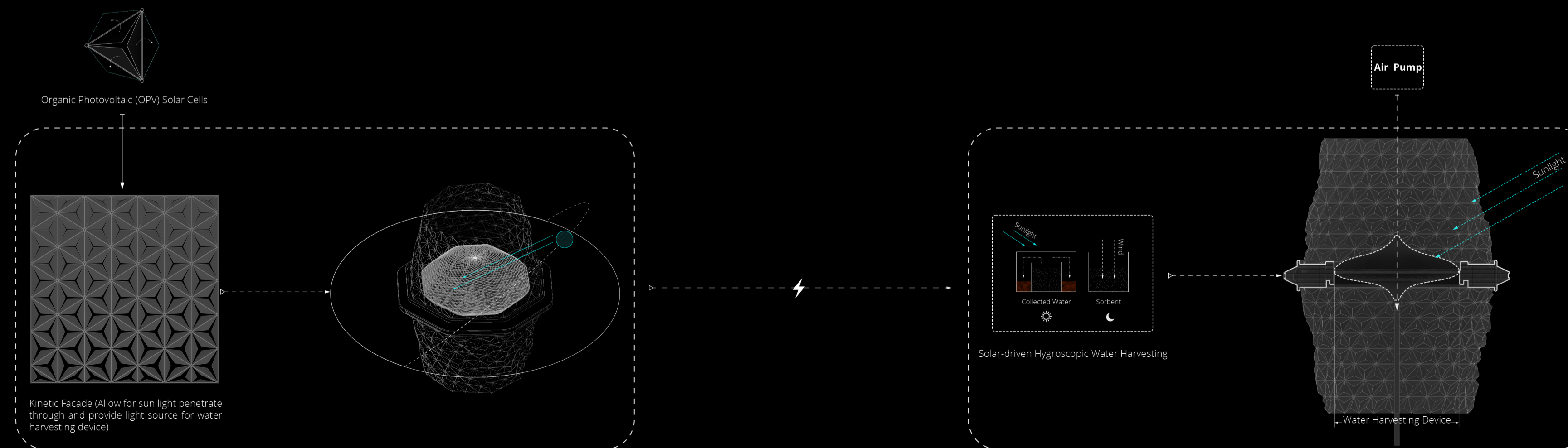

Solar Energy ———→ 22464 Kwh per year

Water Production ———→ 261,654 liters of water per year

Energy Harvesting Process
 When the sun rises, the OPV skin is at its longest status which means it is harvesting solar energy. Meanwhile, the sunlight penetrates the OPV skin to reach the water harvesting device which indicates the process of water harvesting. The OPV triangle pieces on the skin can be adjusted to adapt the Sun's rotation to reach the best energy harvesting status, including harvesting electricity and water.